

2301D-GT

Digital Load Sharing and Speed Control



Applications

The 2301D-GT is a field-configurable control designed for single-shaft gas turbine applications. This control's configurability allows it to be easily applied in a diverse range of single-shaft gas turbine applications.

The 2301D-GT control can be configured as a replacement for Woodward 2301A or 2301A LSSC controls, or for use within new turbine applications.

The 2301D-GT control includes the following basic turbine control functions:

- Speed Control
- Start Fuel Ramp
- Min/Max Fuel Limits
- Overspeed Protection
- Shutdown Logic
- Alarm Logic
- Platform Diagnostics

Alternatively, the following functions can be configured, depending on application requirements (I/O limitations may prohibit selecting all listed functions at once):

- EGT Limiting
- kW Limiting
- CDP Limiting (Accel/Decel)
- Speed Accel/Decel Limiting
- Droop/Isoch Control
- Power/Actuator-Drive Droop
- Load Sharing (with soft load/unload transfer)
- Light-off Detect (with EGT input)
- SPM-A (Synchronizer) Input
- Power Sensor Input (PTs & CTs)
- ServLink (DDE)/Modbus[®]* Communications

An integral RS-232 communications port allows users to interface with the 2301D-GT through industry-standard Dynamic Data Exchange (DDE) or Modbus based protocols. Alternatively a contact can be programmed to allow users to switch between protocols as desired.

A hazardous location version is available.

*—Modbus is a trademark of Schneider Automation Inc.

- Single-shaft small gas turbine applications
- Digital load sharing and speed control
- Droop, kW droop, and isochronous control capability
- Soft load transfer
- CDP accel / decel scheduling
- EGT limiting
- kW Limiting
- PC configurable with Woodward Watch Window software
- Designed for 900–32,000 rpm applications
- Actuator current range of 4–20 mA and 20–200 mA
- 2301A replacement
- Modbus[®] based serial communications

Description

The Woodward 2301D-GT is a microprocessor-based control with integral application software designed for single-shaft gas turbine applications. Like Woodward's 2301A line of controls, this control is housed in a sheet-metal chassis and consists of a single printed circuit board. To facilitate unit retrofits, the 2301D-GT's I/O terminals are located in the same general location as Woodward's 2301A line of controls.

This control is designed to perform the core fuel control functions of a small gas turbine package. The application software is field configurable, allowing it to be configured and modified to meet site-specific requirements.

With more I/O than its predecessor (the 2301A LSSC), the 2301D-GT control also has serial communications, allowing it to easily interface with the package PLC or plant DCS.

The 2301D-GT is configured and serviced (dynamic adjustments made) via a laptop computer connected to the control's RS-232 communications port. These configuration and dynamic settings are set, changed, tuned, and saved via a laptop computer and Woodward's user-friendly Watch Window software program. This Windows® based PC program allows users to set and adjust all application-based parameters, plus upload and download configurations to and from the control.

Control Functions

The Woodward 2301D-GT controls a wide variety of single-shaft small gas turbines used in electrical generator, compressor drive, or pump applications.

Turbine Start-up

The 2301D-GT provides configurable turbine start-up scheduling via a Start Ramp with optional CDP or Speed-Acceleration Limiting. On start-up, the turbine accelerates according to the Start Ramp or CDP or Accel schedules until the speed control loop takes control of the turbine. The CDP and Decel schedules work similarly on turbine shutdown.

Isoch/Droop Operation

When configured for generator drive applications, the 2301D-GT can operate in either an isochronous or droop load mode. In the "Isoch" mode, the 2301D-GT controls plant/unit frequency control by maintaining turbine speed. In the "Droop" mode, the 2301D-GT controls generator load. If the generator is connected to the utility bus while in droop mode, the unit speed will be determined entirely by the bus frequency. If the generator is disconnected from the utility bus, the unit speed will "droop" as the load increase.

KW Droop Operation

If KW droop is configured, the control uses the output from its integral power sensor to sense and control unit load. The control's power sensor output can be monitored via serial communications or through the control's analog readout. If required, any of the control's three configurable relay outputs can be designated as power level switches to drive auxiliary devices or indicators.

Isochronous Load Sharing

The 2301D-GT includes an analog load sharing network input which is compatible with Woodward's 2301A line of controls. The control's soft load/unload transfer function can also be configured to rate limit unit loading and unloading.

EGT Limit

Optionally the 2301D-GT can be configured for EGT limiting. With this functionality, the control accepts a 4–20 mA signal representing turbine exhaust gas temperature (EGT), and via a PID controller limits fuel valve position, to limit the turbine to a maximum exhaust temperature. The maximum EGT limit setting is adjustable on or off line.

kW Limiter

Optionally, the 2301D-GT can be configured to provide generator kW limiting. With kW limiting, the control compares a 4-20 mA load signal to a kW reference value and then limits the fuel valve position using a PID control function. The kW limit is adjustable on or off-line

Accel/Decel Limiters

Optionally the 2301D-GT can be configured for CDP or Speed Derivative limiting. With CDP limiting, the control accepts a 4–20 mA signal representing turbine compressor discharge pressure (CDP), and via a CDP-to-Fuel flow schedule limits fuel valve position. With Speed Derivative limiting, the control senses the derivative (acceleration/deceleration) of the turbine speed via the control's speed input, and through a PID controller limits fuel valve position.

SPM-A Input

Optionally the 2301D-GT can be configured to accept a ± 3 Vdc synchronizing signal. This input is compatible with and intended to be used in conjunction with Woodward's SPM-A synchronizers.

Minimum Fuel/Maximum Fuel Limits

The 2301D-GT control has configurable minimum and maximum fuel limits to limit fuel valve travel during turbine operation. The minimum fuel limit is used to set light-off fuel flow for proper turbine light-offs.

Communications

The 2301D-GT's RS-232 port serves two purposes: to configure and service the control, and to interface with the control through Modbus communications. A Windows based PC program used on a control-connected laptop is used to set and adjust all application-based parameters, plus upload and download configurations to and from the control. Once the control has been configured, an optional switch can be used to switch to ports Modbus protocol. Through Modbus communications, a user can monitor all turbine-specific parameters as well as control the unit (start, stop, etc.) as desired.

Specifications

Woodward Part Numbers:

8273-127

8273-1002

8923-932

2301D-GT Digital Load Sharing and Speed Control, 24 Vdc input

Hazardous location 2301D-GT Digital Load Sharing and Speed Control, 24 Vdc input

Watch Window Installation

Power Supply Rating 18–40 Vdc (SELV)
Power Consumption less than or equal 20 W nominal

Input Supply Voltage 18 V
24 V (nominal)
32 V
Input Supply Current 589 mA
431 mA
319.6 mA

Inrush Current 7 A for 0.1 ms (24 Vdc input)

Steady State Speed Band $\pm 0.25\%$ of rated speed

Magnetic Pickup 100–24,950 Hz

Discrete Inputs (8) 3 mA at 24 Vdc, impedance approximately 5.2 k Ω

Analog Inputs (2) 4–20 mA

Actuator Output 4–20 or 20–200 mA to actuator, software configurable

Analog Output 4–20 mA, internally powered

Discrete Outputs (4) configurable relay drivers, powered by external +12 or +24 Vdc source, max output current 200 mA

Communication Port RS-232, 9-pin connector, 1200 to 38,400 baud, full duplex

Ambient Operating Temperature –40 to +70 °C (–40 to +158 °F)

Storage Temperature –40 to +105 °C (–40 to +221 °F)

Humidity 95% at +20 to +55 °C (+68 to +131 °F)

Lloyd's Register of Shipping Specification Humidity Test 1

Lloyd's Register of Shipping Specification Vibration Test 2

Mechanical Shock US MIL-STD 810C, Method 516.2, Procedure I (basic design test), Procedure II (transit drop test, packaged), Procedure V (bench handling)

Equipment Classification Class 1 (grounded equipment)

Technical Manual 26144

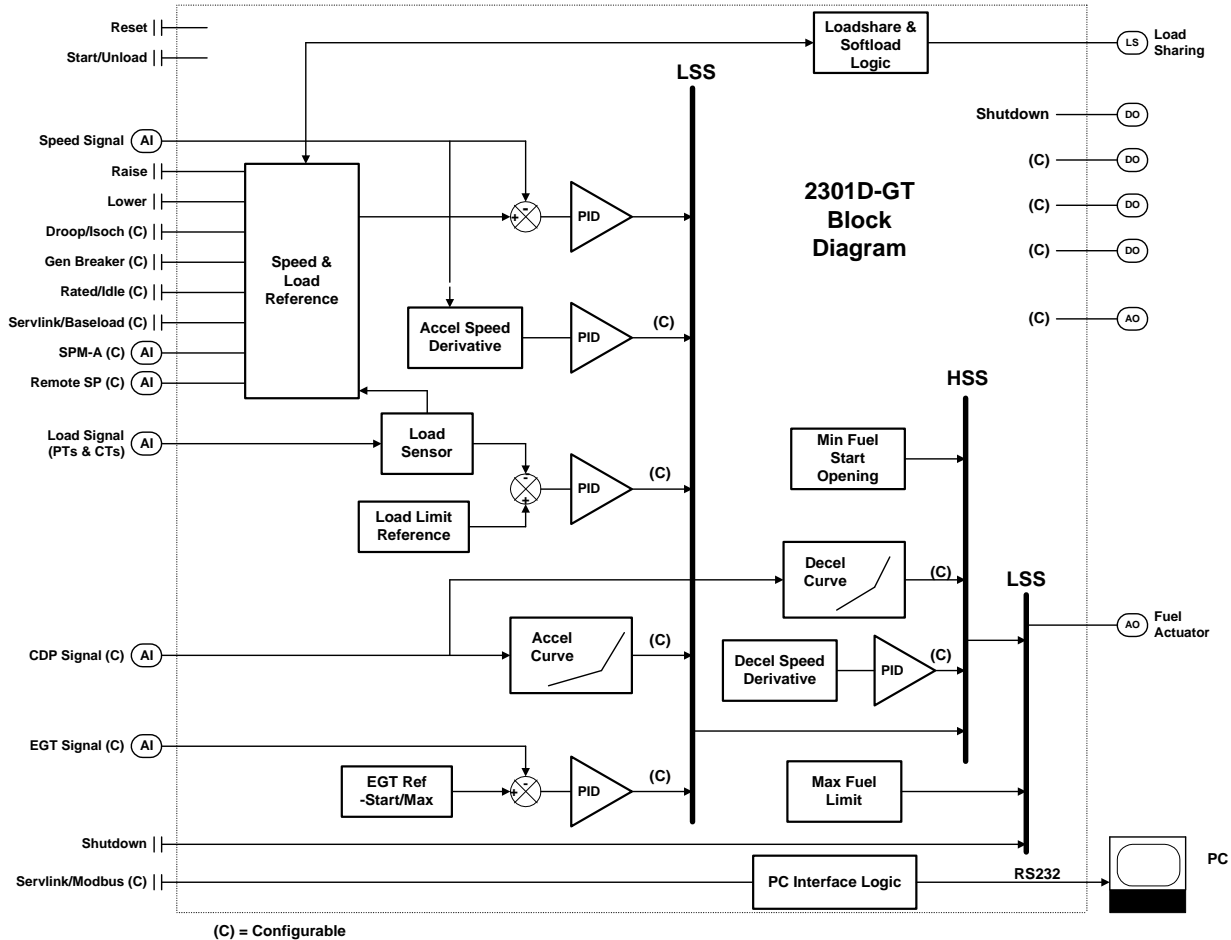

2301D-GT Digital Control Block Diagram

Configurability

The configurability of the 2301D-GT's application software allows such parameters as turbine speed range, gear teeth, and analog I/O functionality, discrete I/O functionality, internal control limits, and actuator output current to be configured off-line and with certain parameters on-line.

Input Signals

Discrete Inputs (8)

Five discrete inputs are assigned predefined functions, and three discrete inputs are configurable:

- External Shutdown
- System Reset
- Start/Unload
- Speed/Load Raise
- Speed/Load Lower
- Generator Breaker Status (P)
- Isoch/Droop Select (P)
- Rated/Idle (P)
- ServLink/Modbus (P)
- ServLink/Baseload (P)

Speed Signal (1)

One magnetic pickup speed signal (900–32,000 rpm)

Analog Inputs (2)

Two Analog Inputs configurable to accept:

- EGT signal (4-20 mA)
- CDP signal (4-20 mA)
- SPM-A (Synchronizer, ± 3 Vdc)
- Remote Speed Setpoint Signal (4-20 mA)

Load Sensor Inputs

- Generator PT Signals
- Generator CT Signals

Output Signals

Discrete Outputs (4)

One discrete output is preset for Shutdown State.

Three discrete outputs can be configured for:

- Shutdown State
- General Alarm
- Speed Reference Min. Limit
- Speed Reference Max. Limit
- Speed Switch #1
- Speed Switch #2
- Load Switch #1
- Overspeed Alarm
- Speed PID In-Control
- EGT PID In-Control
- CDP Limit Reached
- Speed Accel/Decel Limit Reached
- Remote Speed Setpoint Enabled
- Synchronizing enabled
- Light Off Failure
- Starter Energized
- Open Breaker
- Load Limit Reached
- Modbus Controlled Relay #1
- Modbus Controlled Relay #2

Actuator Signal Output (1)

One actuator driver (4–20 mA/ 20–200 mA)

Analog Outputs (1)

One analog output can be configured for:

- Turbine Speed Readout
- Speed Setpoint Readout
- EGT Readout
- CDP Readout
- Generator Load Readout
- Actuator Output Readout

Regulatory Compliance

European Compliance for CE Mark:

EMC Directive

Certified to 89/336/EEC COUNCIL DIRECTIVE of 03 May 1989 on the approximation of the laws of the member states relating to electromagnetic compatibility.

Low Voltage Directive

Certified to the 73/23/EEC COUNCIL DIRECTIVE of 19 February 1973 on the harmonization of the laws of the Member States relating to electrical equipment designed for use within certain voltage limits.

North American Compliance:

CSA

CSA Certified for Ordinary Locations for use in the United States and Canada.

CSA

CSA Certified for use in Class I, Division 2, Groups A, B, C, D (part number 8273-1002 only).

NOTE

Wiring must be in accordance with applicable electric codes with the authority having jurisdiction.

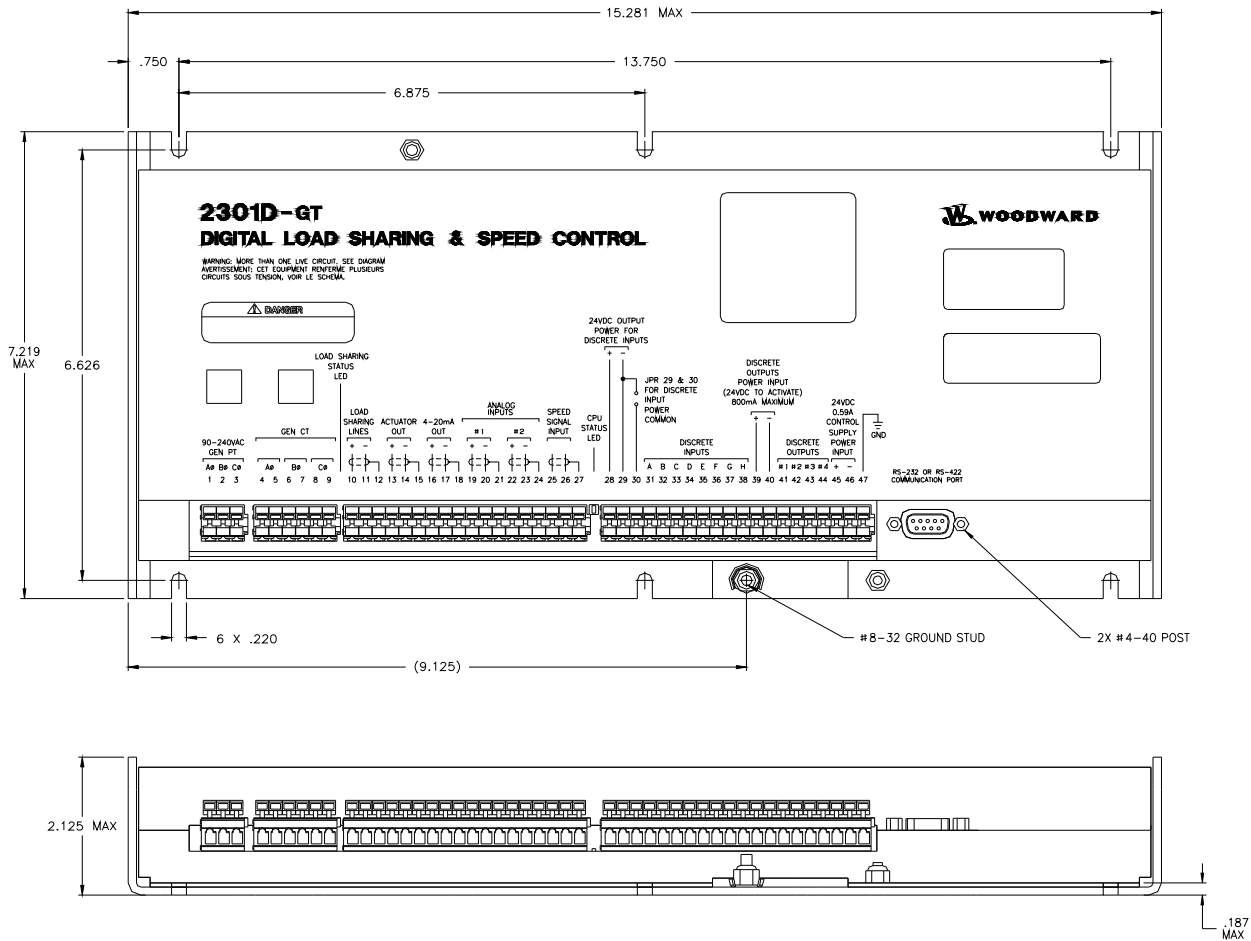

2301D-GT Digital Control Outline Drawing (standard version)
 (Do not use for construction)



	388.0
13.750	349.2
7.219	183.3
6.875	174.6
6.626	168.3
2.125	54.0
.750	19.0
.220	5.6
INCH	MM
INCH TO MM CONVERSION	



PO Box 1519, Fort Collins CO, USA 80522-1519
 1000 East Drake Road, Fort Collins CO 80525
 Tel.: +1 (970) 482-5811 ♦ Fax: +1 (970) 498-3058
www.woodward.com

Distributors & Service

Woodward has an international network of distributors and service facilities. For your nearest representative, call the Fort Collins plant or see the Worldwide Directory on our website.

This document is distributed for informational purposes only. It is not to be construed as creating or becoming part of any Woodward contractual or warranty obligation unless expressly stated in a written sales contract.

Copyright © Woodward 2001–2010, All Rights Reserved

For more information contact: